

120 AG series

x120x25mm

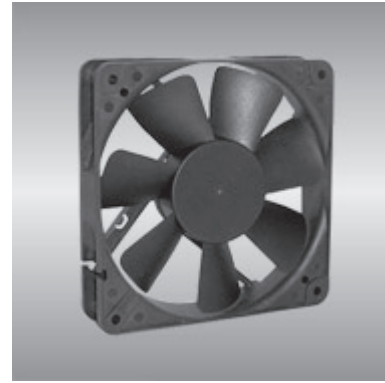

General Specifications

- Motor : 4 Poles brushless DC motor
- Frame & Impeller : Plastic(UL 94V-0)
- Storage temperature : -40° to +75°
- Operating temperature : -10° to +70°

Major Characteristic Parameters

Model	*Bearing System	Rated Voltage	Operating Voltage Range	Rated Current	Rated Speed	Maximum Air Flow		Maximum Static Pressure		Sound Level	Weight
Part NO.	B / S / F	V	V	A	RPM	m ³ /min	CFM	mm-H ₂ O	In-H ₂ O	dBA	g
AGF12025_12L	B S	12	7.0~13.2	0.36	2500	2.60	91.9	5.5	0.22	37.0	165
AGF12025_24L	B S	24	14.0~26.4	0.25	2500	2.60	91.9	5.5	0.22	37.0	165
AGF12025_12M	B S	12	7.0~13.2	0.53	2800	2.92	103.0	6.9	0.27	40.0	165
AGF12025_24M	B S	24	14.0~26.4	0.32	2800	2.92	103.0	6.9	0.27	40.0	165
AGF12025_12H	B S	12	7.0~13.2	0.64	3100	3.23	114.0	8.5	0.33	43.0	165
AGF12025_24H	B S	24	14.0~26.4	0.38	3100	3.23	114.0	8.5	0.33	43.0	165
AGF12025_12U	B S	12	7.0~13.2	0.96	3400	3.54	125.1	10.2	0.40	45.0	165
AGF12025_24U	B S	24	14.0~26.4	0.60	3400	3.54	125.1	10.2	0.40	45.0	165

*Bearing system B: Two Ball Bearing F: Fluid Bearing S: Sleeve Bearing

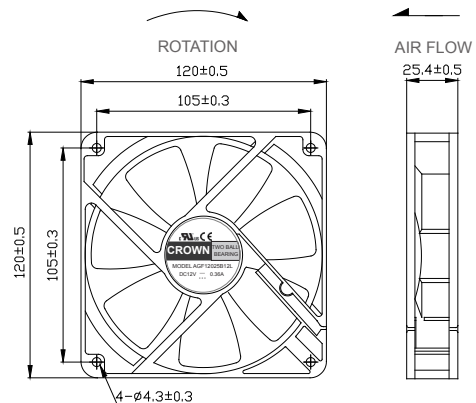
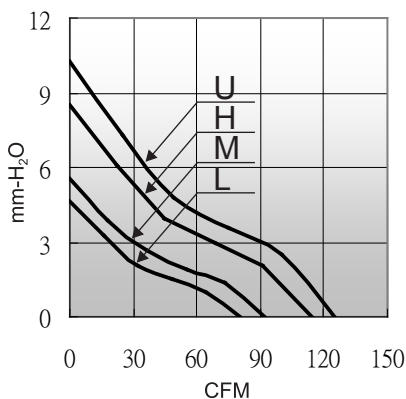

unit:mm